

# ON-SITE GUARDRAIL GARDEN TRAINING

## SoftStop End Treatment Component Checklist

Date Created: 4/1/2024



### SoftStop Inspection Checklist

1. Are all rail panels straight (not curved) between Post 0 and last post (8) within the Soft Stop system?

<b>Answer:</b> Yes / No (circle answer)
<b>Correct Checklist Answer:</b> Yes
<b>Manufacturer Checklist Item: #6</b>
Ensure no rail panels, between Post 0 and last post within the SoftStop® System are curved. (p. 16)



Examples shown below are of a Test Level 3 (TL-3) SoftStop® System Assembly:

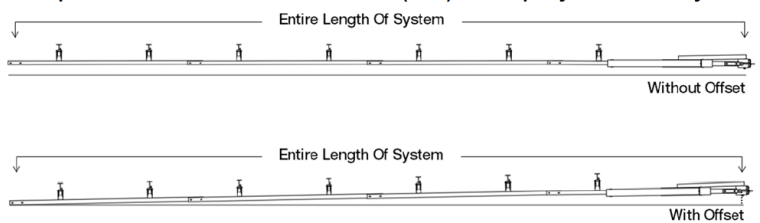

**Caution:** Under no circumstances shall the rail within the SoftStop® System be curved, between Post 0 and the last post of the SoftStop® System.

# ON-SITE GUARDRAIL GARDEN TRAINING

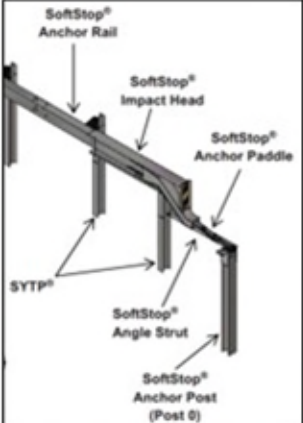

### SoftStop Inspection Checklist

2. Are the centers of the SYTP yielding holes approximately centered at finished grade line for Post 1 & 2?

<b>Answer:</b> Yes / No (circle answer)
<b>Correct Checklist Answer:</b> Yes
<b>Manufacturer Checklist Item: #7</b>
Ensure the center of the SYTP <sup>®</sup> yielding holes are approximately centered at finished grade line for Post 1 & 2. (p. 25)

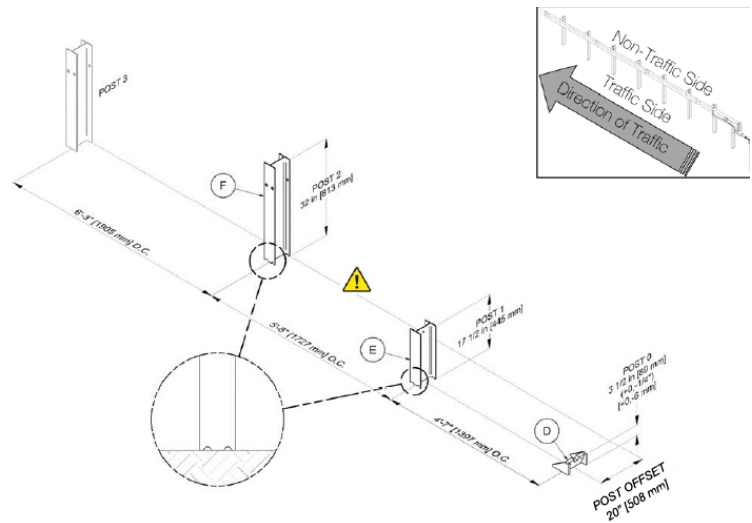

# ON-SITE GUARDRAIL GARDEN TRAINING



### SoftStop Inspection Checklist

3. What is the height of the Anchor Post (Post 0)?

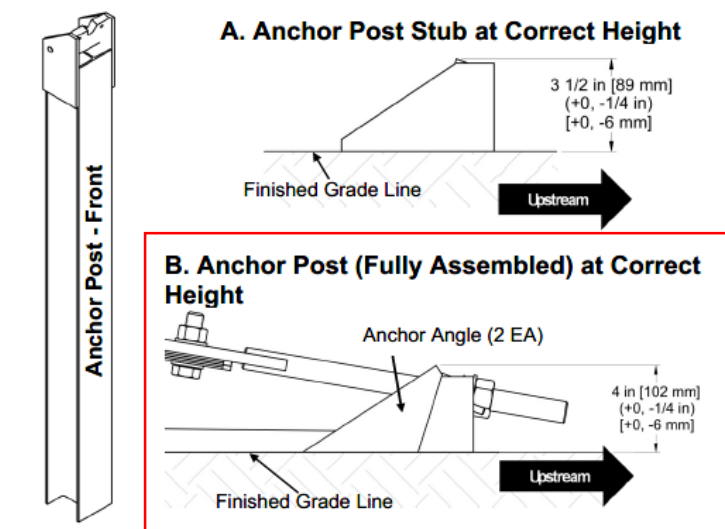

**Caution:** Ensure the SoftStop® System Anchor Post is assembled in the orientation shown above. Failure to follow this warning could result in serious injury or death in the event of a vehicle impact or collision with the system.

<b>Answer:</b> Yes / No (circle answer)
<b>Correct Checklist Answer:</b> 3.75" ≤ [Measurement] ≤ 4.0"
<b>Manufacturer Checklist Item: #8</b>
Ensure the fully assembled SoftStop® Anchor Post (Post 0) has a maximum height of 4" [102 mm] and a minimum height of 3 3/4" [96 mm] above finished grade line. (p. 21)

# ON-SITE GUARDRAIL GARDEN TRAINING



## SoftStop Inspection Checklist

4. Is the anchor rail bolted at post 2?

Answer: Yes / No (circle answer)

Correct Checklist Answer: No

Manufacturer Checklist Item: #9

Ensure that the SoftStop® Anchor Rail is not bolted to Post 2 (SYTP®). (pp. 30-31)

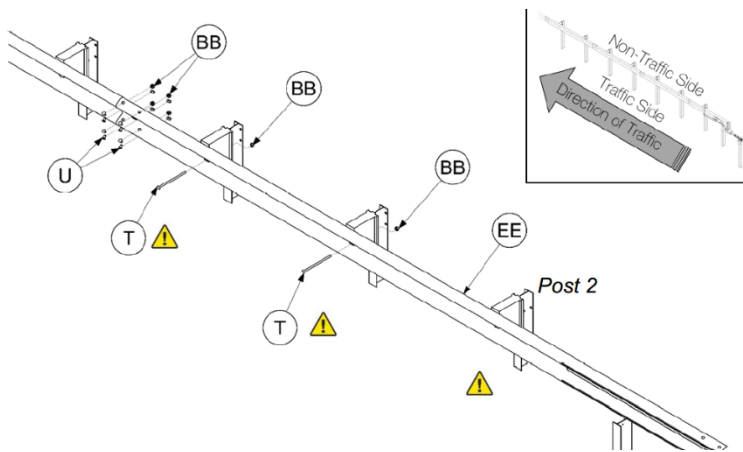



### WARNING



Do not bolt the SoftStop® Anchor Rail to Post 2. Do not place anything between any post bolt head and the SoftStop® System Rail that would prevent the bolt from pulling through. Failure to follow this warning could result in serious injury or death in the event of a collision.

# ON-SITE GUARDRAIL GARDEN TRAINING

### SoftStop Inspection Checklist

5. Is the SoftStop Impact Head Connection Bracket attached to the front side of the SoftStop Post 1 with required 5/16" hardware?

<b>Answer:</b> Yes / No (circle answer)
<b>Correct Checklist Answer:</b> Yes
<b>Manufacturer Checklist Item: #13</b>
Ensure the SoftStop® Impact Head Connection Bracket is attached to the front side of SoftStop® Post 1 (SYTP®) with required 5/16" hardware. (p. 34)

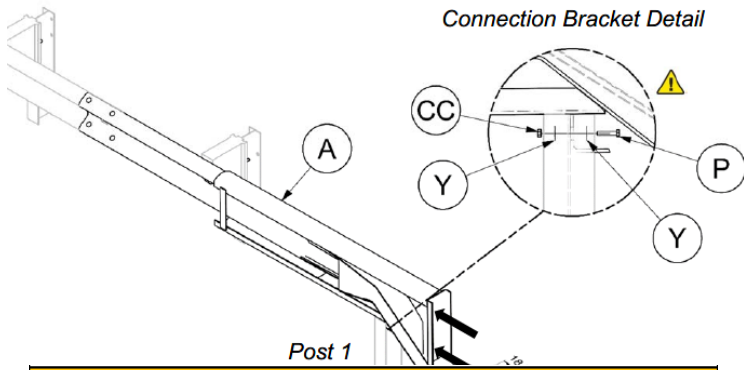

**WARNING**

The SoftStop® Impact Head Connection Bracket must rest against the front side of Post #1 (between Posts 0-1) as shown in the Connection Bracket Detail above.

# ON-SITE GUARDRAIL GARDEN TRAINING

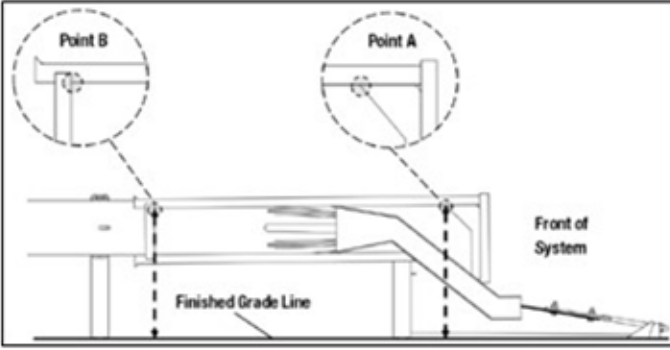

The diagram shows a cross-section of the SoftStop guardrail system. Two circular callouts, 'Point A' and 'Point B', are positioned above the top rail. Point A is at the top of the rail on the right side, and Point B is at the top of the rail on the left side. A dashed line connects the two points. Below the rail, a horizontal line is labeled 'Finished Grade Line'. The front of the system is indicated by an arrow pointing to the right.

### SoftStop Inspection Checklist

6. Record the upward tilt of the SoftStop Impact Head.

<b>Answer:</b> Yes / No (circle answer)
<b>Correct Checklist Answer:</b> [Measurement] ≤ 3.5"
<b>Manufacturer Checklist Item: #14</b>
Ensure SoftStop® Impact Head has no more than 3 1/2" [89mm] of upward tilt. (p. 22)

The SoftStop® Impact Head shall be installed such that the difference between the vertical dimensions at these two reference points (A – B) equals 2 1/4" [58 mm], with a tolerance of + 1 1/4" [32 mm] – 2 1/4" [58 mm]. Thus, the nominal value for A – B is 2 1/4" [58 mm] and the range is 0" [0 mm] to 3 1/2" [89mm].

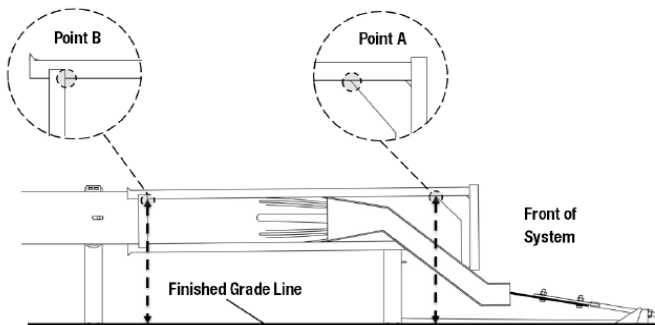

Point A



Point B

# ON-SITE GUARDRAIL GARDEN TRAINING



## SoftStop Inspection Checklist

7. Is the Anchor Paddle installed on top of the SoftStop Anchor Rail and are the two 3/4" bolts utilized are installed from the bottom of the SoftStop Anchor Rail with a washer and hex nut installed on top?

Answer: Yes / No (circle answer)

Correct Checklist Answer: Yes

### Manufacturer Checklist Item: #15

Ensure the SoftStop® Anchor Paddle is installed on top of the SoftStop® Anchor Rail and the two (2) 3/4" bolts utilized are installed from the bottom of the SoftStop® Anchor Rail. (pp. 33 & 36)

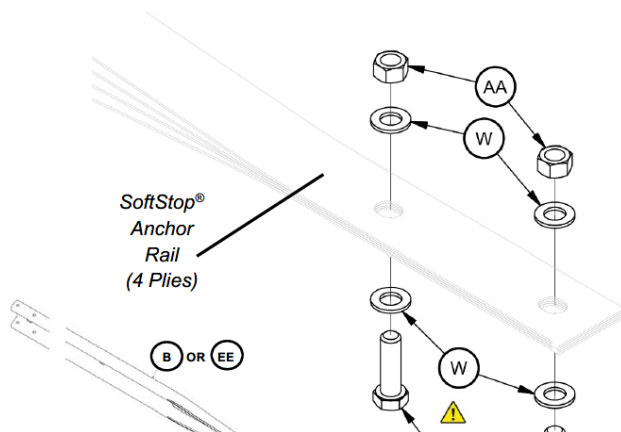

### WARNING



Insert the SoftStop® Anchor Paddle Bolts (Part Q) from the bottom of the SoftStop® Anchor Rail. Failure to follow this warning could result in serious injury or death in the event of a collision.

# ON-SITE GUARDRAIL GARDEN TRAINING

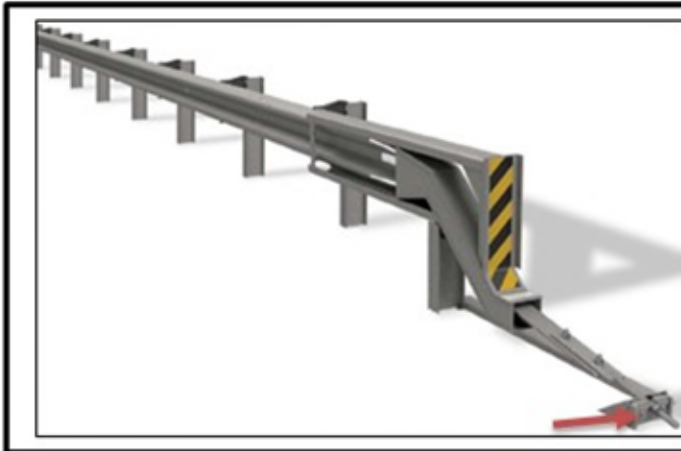

## SoftStop Inspection Checklist

8. Is the SoftStop® Keeper Plate and Plate Washer properly positioned with required hardware?

**Answer:** Yes / No (circle answer)

**Correct Checklist Answer:** Yes

**Manufacturer Checklist Item: #16**

Ensure that the SoftStop® Keeper Plate and Plate Washer are properly positioned with required hardware. (p. 37)

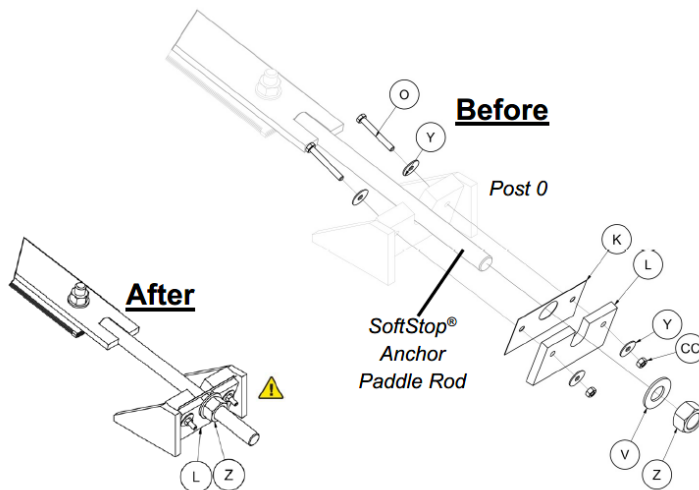

### WARNING



Ensure the 1" Hex Nut (Part Z) has been fully tightened against the SoftStop® Plate Washer (Part L). Failure to follow this warning could result in serious injury or death in the event of a collision.

# ON-SITE GUARDRAIL GARDEN TRAINING

	<b><u>SoftStop</u> Inspection Checklist</b>
	9. Is the the 1" Hex Nut fully tightened (flush) against the SoftStop® Plate Washer?

<b>Answer:</b> Yes / No (circle answer)
<b>Correct Checklist Answer:</b> Yes
<b>Manufacturer Checklist Item: #17</b>
Ensure the 1"Hex Nut has been fully tightened against the SoftStop® Plate Washer. (p. 37)

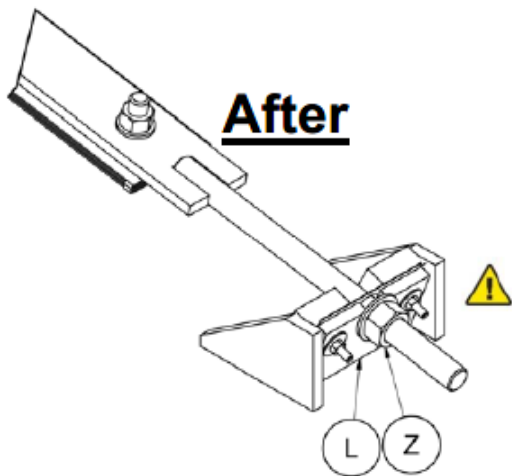

# ON-SITE GUARDRAIL GARDEN TRAINING

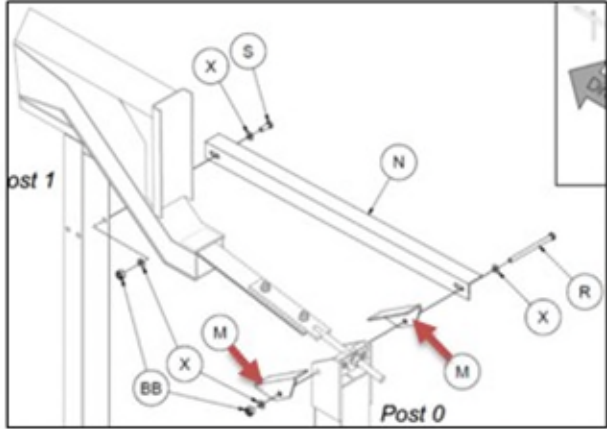
	<p><b>SoftStop Inspection Checklist</b></p> <p>10. Are both SoftStop® Anchor Angles properly positioned?</p>
---	--

**Answer:** Yes / No (circle answer)

**Correct Checklist Answer:** Yes

**Manufacturer Checklist Item: #18**

Ensure that both SoftStop® Anchor Angles are properly positioned. (p. 38)



# ON-SITE GUARDRAIL GARDEN TRAINING



## SoftStop Inspection Checklist

11. Is the SoftStop® Angle Strut properly attached on the non-traffic side with the "toe" of the vertical leg down?

**Answer:** Yes / No (circle answer)

**Correct Checklist Answer:** Yes

**Manufacturer Checklist Item: #19**

Ensure the SoftStop® Angle Strut is properly attached on the non-traffic side with the "toe" of the vertical leg down. (p. 38)

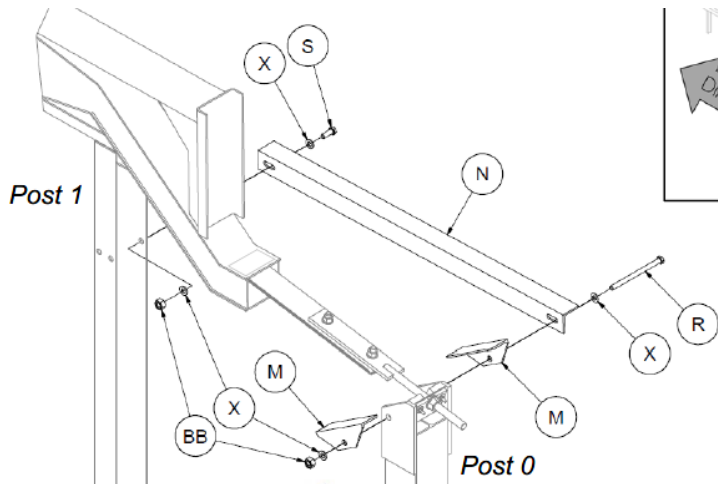

# ON-SITE GUARDRAIL GARDEN TRAINING

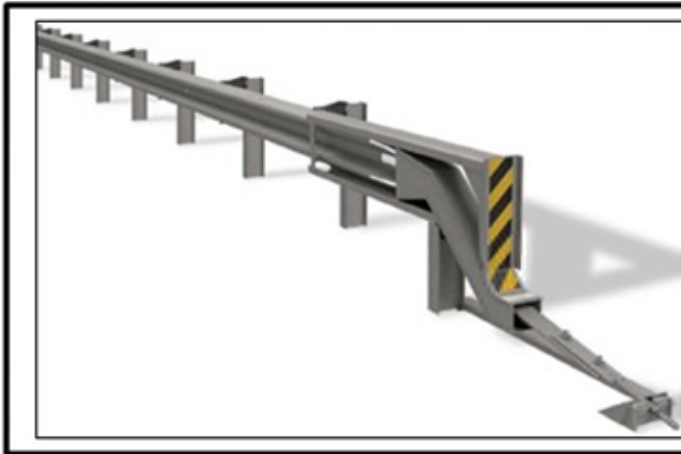

## SoftStop Inspection Checklist

12. Are all fasteners of the SoftStop® System tightened to a snug position with a minimum of two threads protruding beyond the nut?

**Answer:** Yes / No (circle answer)

**Correct Checklist Answer:** Yes

**Manufacturer Checklist Item: #20**

Ensure that all fasteners of the SoftStop® System are tightened to a snug position with a minimum of two threads protruding beyond the nut.

